

WARFIGHTER FABRICATION AXLE HOUSING ORDER FORM

(440)226-9475

SHAUN@WARFIGHTERFABRICATION.COM

Option 1 is for leaf spring, parallel 4 link and ladder bar.

Option 2 is for factory 4 link suspension

If building a new axle without a stock axle to measure off of put the wheels and tires under the car with no axle under the car. Put the wheels where you want them to sit at ride height and measure from the inside of one wheel mating surface to the other for total length. If the pinion is offset in the car draw a line from crank center or output shaft to the rear of the car and measure each side from the line.

AXLE DIMENSIONS

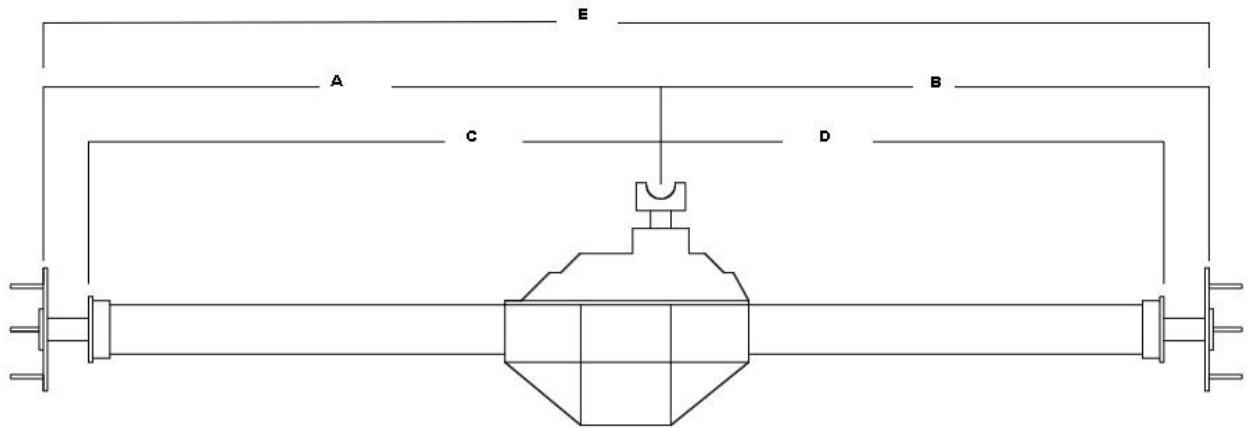

OPTION 1

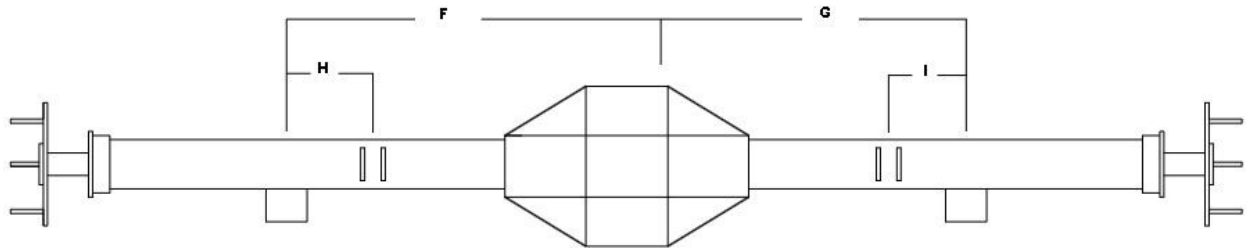

OPTION 2

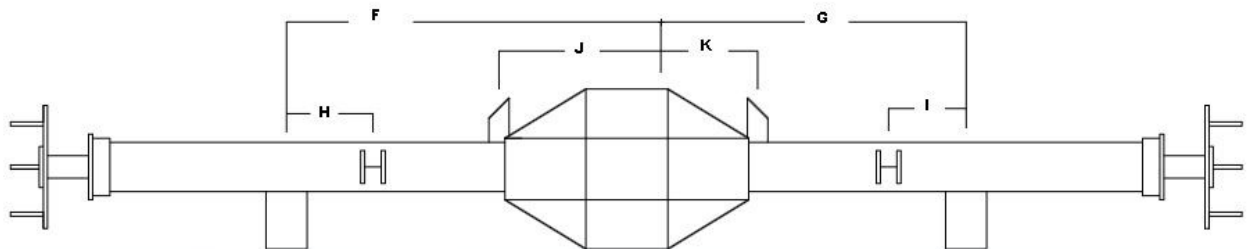

OPTION _____

A. DRIVER SIDE LENGTH TO FACE OF AXLE _____

B. PASSENGER SIDE LENGTH TO FACE OF AXLE _____

C. DRIVER SIDE LENGTH TO FACE OF HOUSING END _____

D. PASSENGER SIDE LENGTH TO FACE OF HOUSING END _____

- E. TOTAL LENGTH _____
- F. DRIVER SIDE SUSPENSION BRACKET TO PINION CENTER _____
- G. PASSENGER SIDE SUSPENSION BRACKET TO PINION CENTER _____
- H. DRIVER SIDE SHOCK MOUNT TO SUSPENSION BRACKET _____
- I. PASSENGER SIDE SHOCK MOUNT TO SUSPENSION BRACKET _____
- J. DRIVER SIDE UPPER MOUNT TO PINION CENTER _____
- K. PASSENGER SIDE UPPER MOUNT TO PINION CENTER _____

Axle lug pattern _____

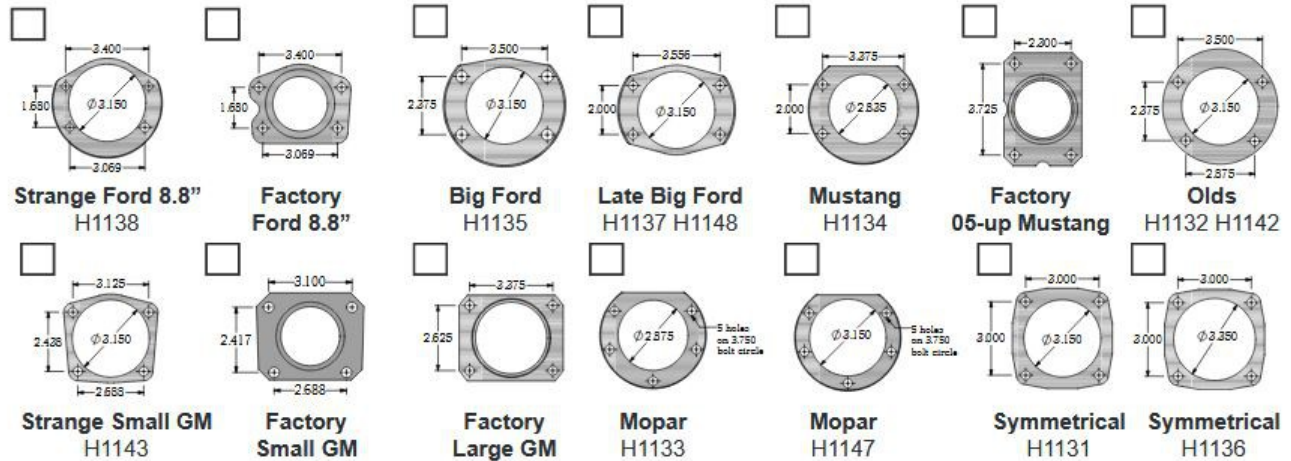

NAME _____
 ADDRESS _____
 PHONE NUMBER _____
 EMAIL _____

After filling out this form scan and send to the email above then call the number above to place the order.